

Playing with Shadows: Reinjection Loops and Historical Allusion in Georg Friedrich Haas's Live Electronic Music

Jouer avec les ombres : boucles de réinjection et allusion historique dans la musique avec traitement numérique en temps réel de Georg Friedrich Haas

Landon Morrison

Les voies de la pansonorité : la musique microtonale d'hier à aujourd'hui
Volume 29, numéro 2, 2019

URI : <https://id.erudit.org/iderudit/1062568ar>
DOI : <https://doi.org/10.7202/1062568ar>

[Aller au sommaire du numéro](#)

Éditeur(s)

Circuit, musiques contemporaines

ISSN

1183-1693 (imprimé)
1488-9692 (numérique)

[Découvrir la revue](#)

Citer cet article

Morrison, L. (2019). Playing with Shadows: Reinjection Loops and Historical Allusion in Georg Friedrich Haas's Live Electronic Music. *Circuit*, 29 (2), 63–82.
<https://doi.org/10.7202/1062568ar>

Résumé de l'article

Les études récentes laissent entendre que la musique du compositeur autrichien Georg Friedrich Haas peut être comprise comme une confrontation dramatique de « systèmes harmoniques contrastants » (Hasegawa, 2015). Prenant cette observation pour point de départ, cet article se concentre sur les tentatives récentes de Haas dans le domaine de la musique avec traitement numérique en temps réel. L'auteur met en lumière les procédures techniques relativement simples que déploie le compositeur – la boucle de réinjection, ou encore la diffusion différée de sons enregistrés à différentes vitesses – pour juxtaposer différents modes d'organisation des auteurs, incluant les douze demi-tons chromatiques, l'ultrachromatisme microtonal et l'intonation juste. Après s'être penché sur la relation que Haas entretient avec ces langages et leurs ancrages historiques, l'article présente des analyses détaillées de deux de ses pièces (*Ein Schattenspiel* et le Quatuor à cordes n° 4) afin d'illustrer comment la boucle de réinjection opère simultanément à de multiples niveaux, permettant à l'interprète d'entrer en contact avec son passé immédiat tout en inscrivant le compositeur dans un dialogue avec les ombres de ses propres prédécesseurs.

Playing with Shadows: Reinjection Loops and Historical Allusion in Georg Friedrich Haas's Live Electronic Music

Landon Morrison

Despite increasingly frequent engagements with the genre over the past fifteen years, Austrian composer Georg Friedrich Haas (b. 1953) is not yet widely known as a composer of electroacoustic music. Thus far, he has written six pieces that incorporate electronic media in some capacity, but none have been the focus of sustained commentary or research. Instead, authors have gravitated toward his works for large instrumental forces, such as the hour-long orchestral behemoth *in vain* (2000), which was met with overwhelmingly positive reviews. Acclaimed conductor Sir Simon Rattle declared *in vain* to be an “astonishing work of art [...] one of the only already acknowledged masterpieces of the twenty-first century.”¹ Likewise, in the popular press, a number of writers have praised this work and others like it, marveling at Haas’s ability to channel “Wagnerian intensity” (Woolfe, 2014), his “visceral feeling for the elemental ebb and flow of sound” (Ross, 2010), and his “uncanny command of texture and tone color and the emotional weight he wrests from subtle intonation games” (Fonseca-Wollheim, 2016). Even within the slow-moving currents of academic publishing, there has been a surge of interest in his music, with recent scholarship by Lisa Farthofer, Robert Hasegawa, Simone Heilgendorff and others paving the way for a more historically and theoretically grounded understanding of his unique musical style.²

One compelling idea that has emerged from this initial wave of research is the argument that Haas’s music synthesizes diverse compositional approaches in a manner that defies the system-building principles of his modernist predecessors.³ The present article builds on this observation by examining how

1. Rattle made this bold proclamation in a program note for the performance of Haas’s *in vain* by the London Sinfonietta on December 6, 2013. Within days, Tim Rutherford-Johnson published a stinging critique of Rattle’s claim, arguing that the work is hardly flawless beyond criticism, and that attempts to put it on a pedestal are out of step with a “post-(post-) modern culture” that should “move beyond this sort of language” (2013).

2. Published studies of Haas’s music include a full-length book (in German) by Farthofer (2007), an article in *Music Theory Spectrum* by Hasegawa (2015), and a recent book chapter by Heilgendorff (2017). In addition, Haas’s music has been the focus of several conference presentations at the annual meeting of the Society of Music Theory; these include papers by Amy Bauer (2014), William Mason (2017), and the present author, who delivered an earlier version of this article at a 2017 SMT session dedicated to “The Music of Georg Friedrich Haas.”

3. In his 2015 article, Hasegawa identifies “clashing harmonic systems” in the context of the aforementioned *in vain* and *Blumenstück* (2000) for

choir, tuba, and string quintet. In both cases, he shows how Haas creates “large-scale form by dramatizing the opposition between equal-temperament and just intonation” (p. 204).

4. Wyschnegradsky, 1954.

5. Haas, 2007, p. 128.

6. Varga, 2011, p. 102.

7. Haas, 2003.

8. These four approaches to microtonality are first outlined in Haas’s 1999 essay “Jenseit der Zwölf Halbtöne,” but they are expounded in fuller detail in his 2003 article, “Mikrotonalitäten.” They resurface in slightly expanded form in a 2007 article titled “Mikrotonalität und spektrale Musik seit 1980”; in this final incarnation, Haas expands the first category to cover all types of “scales,” further dividing this new heading into subcategories such as non-European scales, equal divisions of the octave, and irregularly structured scales.

this aesthetic pluralism is expressed in his live electronic music. Detailed analyses of two works—*Ein Schattenspiel* for piano and live electronics (2003) and String Quartet No. 4 (2004)—reveal how his deployment of a relatively straightforward tape delay procedure known as the *reinjection loop* brings different harmonic systems into dialogue. In doing so, he activates a vast historical network, saturating his first works of mixed music with explicit and hidden references to the musical past. These references will be surveyed in the first half of this article: first through a close reading of the composer’s own public statements, and then through a comparison with what Russian composer Ivan Wyschnegradsky (1893–1979) called *la loi de la pansonorité*.⁴ After considering the nature of these historical connections, the text returns to focus on Haas’s novel use of the reinjection loop, demonstrating how he adopts the procedure not only as a technical tool for engineering musical form, but as a hermeneutic device for re-presencing the past on a number of different registers. Concentrating on his earliest mixed works, this paper seeks to draw attention to a neglected area of his compositional output and to show how, even as it expands into a new artistic medium, his music maintains its connection to a wide array of historical musical traditions.

Historical Allusion in Haas’s Compositional Style

The coexistence of diverse compositional influences in Haas’s music can be confounding for critics trying to situate him within a specific stylistic lineage. For many, his music falls within the bounds of spectralism, but Haas has resisted this characterization, arguing: “Yes, I use overtone spectra, but I would protest against being called a spectralist.”⁵ He has also rebuffed those who would reduce his music to its microtonal elements, claiming: “I am not really comfortable with being pigeonholed as a microtonalist composer. Primarily I am a composer, free to use whatever means I need for my music.”⁶ Statements like these suggest an image of Haas as a maverick whose music defies neatly prescribed categories, placing it in a class of its own. But his rejection of aesthetic purity should not be taken as a claim of complete autonomy, and Haas concedes as much in a 2003 essay titled “Mikrotonalitäten,” where he argues that his music draws freely from a wide variety of microtonal traditions.⁷ In making his case, he sketches a capsule history of microtonal music, reducing its imposing scope to four generalized approaches. These include 1. tempered subdivisions of the octave, 2. orientations around the proportions of the overtone series, 3. sound-splitting techniques (*Klangspaltung*) that produce beating effects between near-unison pitches, and 4. aleatoric approaches that yield unpredictable pitch content.⁸ For each category, he

identifies a number of representative composers. Notable examples of the first approach include Wyschnegradsky, Alois Hába, Richard Heinrich Stein, and Julián Carrillo; the second approach pertains to Harry Partch, La Monte Young, and James Tenney; the third derives primarily from the music of Giacinto Scelsi; and the fourth relates to the kind of indeterminate pitch material found in John Cage's prepared piano works, or in the unpredictable results of certain extended instrumental techniques. Moving beyond microtonality, Haas claims influence from no fewer than forty-four other composers, ranging from Perotin to Helmut Lachenmann and covering nearly every historical period in between. And finally, after exhausting the Western canon, he expands his survey to include several non-Western musical traditions, as well as extramusical sources such as the droning hum of water coolers, transformer stations, and electric razors.

To be sure, Haas's rehearsal of compositional predecessors stretches to the brink of absurdity. Nevertheless, the goal of his rhetorical flourish is clear: anyone who would attribute his music to a single style is missing the big picture, according to which his music can be seen as an amalgam of historical elements, microtonal and otherwise. The aesthetic effect of this hybridized dialect is to create a relational space where historically situated idioms may enter into direct contact with one another. Indeed, Haas has been known to quote explicitly from outside sources, grafting old musical texts into new settings.⁹ But more commonly the origins of his material are obscured through an abstraction of musical essences that allows him to engage with the past on a more subtle and refined level. This tendency to synthesize meta-textual strains of influence into new modes of musical expression challenges traditional notions of unity, reconfiguring the relationship between an authorial self and its others.

One way of framing Haas's pluralist attitude is in relation to the law of pansonority (*loi de la pansonorité*) proposed by Wyschnegradsky. Rejecting the hierarchies and inherent dualisms of tonality, as well as the restrictive limitations of dodecaphony as practiced by the Second Viennese School, Wyschnegradsky embarked on a life-long project to conquer an ultrachromatic universe he deemed "infinite, continuous, and uniform."¹⁰ This meant casting off the constraints of *a priori* pitch systems and nature-based idealism to arrive at an absolute sonic continuum residing in the realm of pure mathematical abstraction. From this virtual space of all possible sounds, Wyschnegradsky methodically investigated the potentialities of specific systems, moving via successive subdivisions toward increasingly diminutive microtonal spaces. While in practice the composer primarily wrote music

9. For instance, Haas quotes unfinished fragments of Mozart's Requiem (K. 626) in his choral work *Sieben Klangräume* (2005) and uses Schubert's unfinished Piano Sonata in C (D. 840) as the basis for his orchestral work *Torso* (2001).

10. Wyschnegradsky, 1954, p. 118. As Pascale Criton notes in the preface to the 1996 republication of this text (p. 22), the notion of *pansonorité* draws heavily on Bergsonian distinctions between virtual and actual, continuous and discrete; these philosophical precepts map neatly onto Wyschnegradsky's opposition between an unknowable infinitude of sound and the perceptible patterns that one hears in actualized musical contexts.

11. For Wyschnegradsky, the progression toward finer tuning systems was a slow and premeditated process: “I had to conquer the world of quartertones, dominate it, then that of the sixths; first the binary, then the ternary, two types of imbalance in relation to twelve. You have to go further [...] so we have the quartertone, the sixth-tone, and their synthesis, the twelfth-tone, a system that would break the sound into twelve parts.” (Wyschnegradsky, 1978, interview with Daniel Charles on Radio France, in Wyschnegradsky, 2013, pp. 455–66).

12. Contrasting his approach to previous models, Wyschnegradsky claims: “For a pansonorous musical consciousness, there are no legitimate or illegitimate sound combinations. Nothing is forbidden *a priori*, everything is legitimate and the choice of one chord over another is no longer conditioned by the abstract rules of harmony, but becomes a problem of musical form” (1954, p. 110).

13. Haas, 1993a and 1993b. Incidentally, Haas uses the same instrumental combination in his work *limited approximations* (2010), a “concerto for six pianos tuned a twelfth-tone apart and orchestra.”

14. Haas, 1993b, p. 88.

15. Haas has been clear on this point, endorsing “the exciting technique of playing different pitch systems against one another, for example, music in the tempered twelve-tone system against overtone chords. Or quartertones against multiphonics. Or slow *glissandi* against static chords, however, they may be structured.” (2007, p. 129).

within the quartertone system (i.e., twenty-four tones per octave), he occasionally ventured into equal-tempered systems based on third-tones (eighteen tones per octave), sixth-tones (thirty-six tones per octave), and ultimately twelfth-tones (seventy-two tones per octave), a system he considered ideal for its ability to integrate both binary and ternary sub-structures.¹¹ But his goal was not to pack as many notes as possible into a given space; rather, he set out to discover new ways of bringing microtonal pitches into musically meaningful relationships.¹² For Wyschnegradsky, the law of pansonority opened up an infinite field of possibility, allowing for the simultaneous existence of multiple sound environments and giving the composer the ability to move freely among them.

The influence of Wyschnegradsky’s theories on Haas’s compositional practice is well documented. Aside from identifying the elder composer as a key historical figure in his writings on microtonal traditions, Haas has penned two extended essays on Wyschnegradsky’s music—one offering an overview of ultrachromaticism and non-octaviating spaces, the other covering Wyschnegradsky’s meticulous approach to microtonal harmony in *Are-en-ciel*, Op. 37 (1956) for six pianos tuned a twelfth-tone apart.¹³ In the latter text, Haas explores the possibility of a dialectic movement between continuous and discrete pitch spaces, arguing that “the boundaries between tonal space and the continuum are fluid.”¹⁴ It follows that composers may travel across this differential threshold, selecting which zones of the pansonorous continuum they wish to inhabit as they move from abstract potentials to concrete systems. Ostensibly, this selection process is only restricted by the innate limits of human perception (e.g., frequency range of hearing), the hardwired constraints of physical instruments, and the creative imagination of the composer.

While both Wyschnegradsky and Haas subscribe to the liberating effects of a greater sonic awareness, it would be an oversimplification to draw an equivalence between the two composers. There are several key differences. In particular, Wyschnegradsky’s method for actualizing pitch spaces is guided solely by the regular division of a total continuum. Haas, on the other hand, is happy to combine equal-tempered systems with overtone chords, not to mention incorporating sound-splitting techniques and aleatoric pitch content.¹⁵ With the benefit of historical hindsight, Haas takes advantage of the full range of options available to a contemporary composer, borrowing models without concern for theoretical consistency. His approach to navigating the continuum can be understood as an extension of Wyschnegradsky’s project, but whereas Wyschnegradsky freed himself from pre-existing models

by devising a system of equal-tempered microtones, Haas is skeptical of all compositional orthodoxies, preferring to carve the pansonorous continuum into a variety of freely chosen pitch spaces.

Reinjection Loops in Haas's Live Electronic Music

In the following, I will consider how the diverse compositional influences outlined above are manifest in Haas's recent work with electronic media. The two pieces under consideration—*Ein Schattenspiel* and String Quartet No. 4—represent his first contributions to the mixed music genre, and both involve real-time interaction between the performer and electronics. Unlike most mixed music, however, the live electronics in these works do not augment or color the sound palette with prerecorded audio or complex sound effects;¹⁶ rather, the sounds of the acoustic instruments are reproduced as accurately as possible, with modifications arising from the application of an anachronistic tape delay procedure.

In its simplest form, the reinjection loop involves recording a live sound on one tape machine, sending the tape to a second machine for playback, and then looping it around again to the first machine, where a new sound is layered on top.¹⁷ Within this configuration, the amount of delay can be controlled by changing the length of tape between the two machines, while a change to the playback speed of the second machine alters both the tempo and transposition of the recorded sound. Haas's implementation of this procedure replaces reel-to-reel tape machines with a PureData software patch, which simulates a tape music paradigm by maintaining the inherent coupling of time and pitch parameters.¹⁸ It is striking that in an age of near-infinite digital potential, he limits himself to well-worn techniques that have been used for over half a century. In doing so, he harkens back to early tape music pioneers such as Terry Riley, Steve Reich, and Pauline Oliveros, adding another historical connotation to his compositional palette. At the same time, on an extramusical level, his restrained use of technologies imparts an archaeological dimension to these works, highlighting a process of remediation by which the content and functionality of older media are embedded within the confines of a new media environment.¹⁹

In light of this orientation to the past, my analysis of Haas's live electronic music shows how the reinjection loop is used as a catalyst for "replaying" history on multiple, variegated time scales. The most immediate and aurally salient instance of this tendency is the way that the technique produces shifting temporal interactions between the performers and their recorded past. The reinjection process imparts a recursive element to the unfolding musical

16. Haas's later mixed works go much further in exploiting the full potential of electronic sound processing. In particular, synthesized sounds move to the foreground in two works that constitute what might be called a middle period within Haas's still-nascent corpus of mixed music—*Les temps tirillés* (2008) and ... *und ...* (2009). And in his most recent mixed piece, String Quartet No. 7 (2011), he explores heavily saturated, artificial textures by processing the strings with a granular synthesis effect.

17. For a more detailed explanation of this tape procedure, see Keane, 1980, p. 55.

18. Additionally, Haas's use of software to imitate the behavior of reinjection loops means that the "loop" is closed acoustically, rather than materially via tape; in other words, sounds played by the second "tape machine" in his setup are not physically relayed back to a first "machine"—they are picked up by a microphone placed in the piano, registering as ambient sounds in the concert hall.

19. In this sense, Haas's use of the reinjection loop resonates with recent trends in new media art that call awareness to the materiality of the medium itself. For more on remediation, see Bolter and Grusin, 1998.

form by repeatedly inserting previous material into the accruing thickness of an ongoing present. Construed programmatically, this process lends an element of dramaturgy to the music as the performer(s) are confronted with the spectres of their own “shadows.” And at the level of large-scale pitch organization, it allows Haas to augment the tonal bandwidth afforded by acoustic instruments, as well as to bring different harmonic systems into dialogue. In this way, he conjures the long shadows of his own predecessors, inviting them into a shared space that signifies the persistence of the past in his ongoing efforts to break new ground.

***Ein Schattenspiel* (2004)**

As the title suggests, *Ein Schattenspiel* follows an extramusical program, which Haas describes as a “confrontation with one’s own past.”²⁰ Adopting the “shadow play” as a constructive allegory, he translates the phenomenon from spatial to temporal terms in order to stage a dramatic opposition between the performer and their sonic “shadow” in the live electronics. Figure 1 outlines the overall form of the piece, illustrating how he evokes this underlying narrative through a relatively straightforward use of the reinjection loop (or *Delay-basierter Transpositionseffekt*, as he refers to it in the technical rider to the score).

20. Haas, 2007, p. 129.

FIGURE 1 *Ein Schattenspiel*, overall form diagram showing how the piano is recorded into a single audio buffer (solid line), delayed for a period of time, and then reinjected at a slightly accelerated tempo (dashed line).

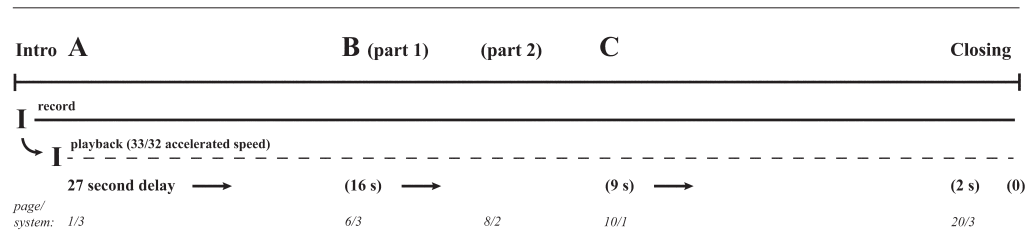

21. The score is mostly unmeasured, so sectional proportions in the form diagram are relative to the performed duration of the work with page numbers and systems indicated below.

Structurally, the work divides into three non-repeating sections, each articulated by its own internal content and self-contained processes.²¹ Within this through-composed form, the reinjection loop runs continuously from start to finish, so that everything played by the performer is recorded into a single audio buffer (I), briefly delayed, and then re-played at a slightly accelerated ratio of 33/32 as compared to the original. The result is that all pitches are transposed upward by a quartertone, yielding a composite quartertone

tuning system between the performer and the electronics.²² This system is an unmistakable reference to the ultrachromaticism of Wyschnegradsky, suggesting another intriguing parallel between the two composers. Like Haas, Wyschnegradsky faced the problem of performing quartertone music on existing instruments, and he envisioned a solution in what he referred to as *l'instrument mécanique*.²³ In 1921, he ordered a pneumatic transmission player piano from Pleyel & Company that was specially designed to accommodate the use of microtones.²⁴ Later, when the instrument proved unsatisfactory, he travelled to Germany, where he consulted with Hába and other microtonalist composers before devising a custom-built quartertone piano that was manufactured by the A. Förster Company. The instrument included two sound boards supporting two sets of strings, along with three keyboard manuals meant to facilitate playability. Ultimately, however, the physical demands the piano placed on performers were too great and its novelty limited performance opportunities. Wyschnegradsky reverted to his prior practice, using two pianos tuned a quartertone apart, which he effectively demonstrated in his landmark *Twenty-four Preludes*, Op. 22a (1934), and in later works such as the *Étude sur les mouvements rotatoires*, Op. 45a (1961).²⁵ These works set a precedent for Haas, who used an identical instrumental configuration in his first set of pieces composed with quartertones, *Trois Hommages* (1982/84).²⁶ Although these pieces are dedicated to György Ligeti, Josef Matthias Hauer, and Steve Reich, one senses the ghostly presence of Wyschnegradsky as an unnamed fourth dedicatee. In light of this historical connection, Haas's use of a tape delay procedure to obtain a quartertone tuning system in *Ein Schattenspiel* can be understood as part of a long-running quest for practical instrumental solutions to the problems posed by microtonality.

Aside from determining pitch content, Haas's highly regulated use of the reinjection loop in this work conditions the types of temporal interactions that are possible between the performer and live electronics. The accelerated playback speed causes a continuous contraction process, in which an initial 27-second lag between the two sources gradually decreases to the point of imperceptibility. The result is a spiraling form where the performer plays in tandem with previous material at ever-shortening time intervals. Though in a different stylistic context, the continuity of this process is reminiscent of Reich's description of "pieces of music that are, quite literally, processes [...] though I may have the pleasure of discovering musical processes and composing the musical material to run through them, once the process is set up and loaded it runs by itself."²⁷ In similar fashion, the contraction process in *Ein Schattenspiel* barrels toward its inevitable conclusion with no hint of external

22. The accelerated ratio of 33/32 yields a pitch transposition that is analogous to the distance between the thirty-second and thirty-third partials in a harmonic series—an interval of 0.53 semitones that closely approximates the quartertone.

23. As Wyschnegradsky recognized early in his career, "current musical instruments are not adapted to a complete artistic realization of the spatial conception that characterizes the practice of ultrachromaticism and the manipulation of sound masses as compact and extensive as those found in the [pansonorous] continuums." (1954, p. 129)

24. *Ibid.*, p. 293.

25. The latter work appears to have been especially influential for Haas, as he dwells at length on its prominent use of interval cycles in one of his early essays on Wyschnegradsky's music (1993b, pp. 83–84).

26. For a fuller discussion of these three early pieces, see Hasegawa, 2014.

27. Reich, 2002 (1968), p. 9.

intervention. The overall effect is of a game of cat-and-mouse between the performer and his/her sonorous “shadow”—a game that ends when the latter finally catches up with the former.

The excerpt in Figure 2a shows the transposed reinjection of a descending sixteenth-note gesture (performed live on the piano at the start of Section A), now sounding a quartertone higher due to the sped-up playback. The top system shows the live electronics and the bottom system shows the performer’s part. Although octave displacements obscure the pattern, the thematic gesture comprises a cascading series of tritone dyads that are repeatedly sequenced down by semitone. As the sequence descends, the harmonic texture thickens, precipitating a thunderous arrival at the bottom of the instrument’s register. In an interesting twist, the electronics seem to *initiate* the action in this excerpt with the reinjection of previously played material, while the performer enters only four sixteenth notes later and repeats the pitches of the electronics a quartertone lower and with a sixteenth-note lag. Haas makes it sound as though the performer is imitating the electronics,

FIGURE 2a *Ein Schattenspiel*, Section A (p. 2, second system), first reinjection of descending sixteenth-note gesture in the live electronics (top staff) with “imitation” in piano part (lower staff). The piano plays in “exact parallel with the electronically transposed piano part,” with a canonic delay of one sixteenth note.

Reinjection of previously played piano gesture, sounding a quartertone higher than written

exakt parallel mit der elektronisch transponierten Klavierstimme

*

20.

FIGURE 2b Imperfect and perfect binary divisions of Wyschnegradsky's *espaces non-octavians*.

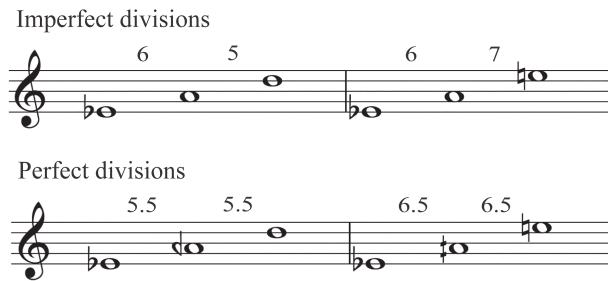

skewing the arrow of causality between the two sound sources. As a result of this maneuver, two or three notes are subtracted from the original idea each time it returns. The idea erodes over the course of nine phrase repetitions until, by the end of Section A, all of the musical material has been stamped out. There is a certain predictability to the formal trajectory of this section; after the liquidation process runs its course, there is nowhere to go—the only way forward is to close the section and begin another.

Aside from its shifting temporal relations, another important aspect of this passage is the tuning offset that arises between performer and electronics. What begins as crisp twelve-tone tuning gradually shades into murkier quartertone territory. The chordal structures thus produced illustrate what Haas refers to as “Wyschnegradsky chords,” which are harmonies built from interval cycles that move through near-octave pitch spaces.²⁸ These chords pervade Haas’s harmonic language and can be traced back to Wyschnegradsky’s systematic exploration of *espaces non octavians*. Pictured in reduced form in Figure 2b, this system centers on microtonal alterations to the perfect octave, contracting inwards to a major seventh (*octaves contractées*) and expanding outwards to a minor ninth (*octaves dilatées*).²⁹ In *Ein Schattenspiel*, Haas uses both major sevenths and minor ninths, neither of which can be divided perfectly within the piano’s twelve-tone equal-temperament tuning (see the top row of Figure 2b). Instead, lopsided approximation must be made, such that a major seventh divides into a perfect fourth plus a diminished fifth, and a minor ninth divides into an augmented fourth plus a perfect fifth. By contrast, in a quartertone framework (bottom row), these non-octaviating spaces divide evenly into eleven and thirteen quartertones, respectively.³⁰ Such perfect binary divisions of near-octave spaces play a prominent role in *Ein Schattenspiel*, and it’s here in

28. Haas, 2007, p. 129. These types of harmonies feature prominently in many of Haas’s works; as Hasegawa (2015) shows, they appear in the equal-tempered sections of *in vain*, and Mason (2017) notes their occurrence in *limited approximations*.

29. A more complete explanation and illustration of Wyschnegradsky’s system can be found in his extended essay titled “Ultrachromatisme et espaces non octavians” (1972; see especially the diagram on pp. 104–5).

30. Within a quartertone system, it is also possible to produce near-octave intervals of 11.5 and 12.5 semitones, but these are not prevalent in *Ein Schattenspiel* and are thus excluded from the present discussion.

31. Wyschnegradsky, 1980 (1932), p. 20.

32. Haas has remarked on using this type of coarse-grained *glissandi* effect in other works, such as *limited approximations* for six microtonally tuned pianos and orchestra (see program note, 2010).

33. Here, as in the first section, there is a strong element of predictable process, with the primary difference being the parameter to which the process is applied. In Section A, a gradual subtractive process is applied to the cyclic phrase structure, allowing the listener to predict the direction of the form. By contrast, Section B is based on a continuous expansion of pitch space in both directions.

34. Wyschnegradsky, 1972, p. 101.

Section A that they make their first appearance. Looking closely at the first vertical simultaneities formed between the electronics and piano, it is clear that Haas exploits the quartertone offset of the two sound sources to create perfect binary divisions of Wyschnegradsky's "contracted" octaves. The two sound sources interlock around major seventh frames, forming dense chordal stacks comprised of eleven quartertone interval cycles. Then, as the gesture continues to unfold, close microtonal clusters are introduced, producing a proliferation of blurred pitch centers similar to what Wyschnegradsky called "plural tones, or expressive unisons."³¹ A noticeable smearing effect is caused by having multiple versions of the same pitch, and the overall impression is of a "pseudo-glissando" achieved through exceptionally choreographed ultrachromatic voice-leading.³²

The Wyschnegradsky chords become more pronounced in Section B, which is organized in two parts, each making use of a similar sequencing technique. In the first part (see Figure 3a below), interactions between the piano and electronics become more nebulous and a greater share of agency is shifted to the performer, who is asked to improvise on fixed pitch collections using variable articulations and dynamics. Pitches are indicated in a series of harmonic modules, each of which contains a stack of major sevenths (i.e., Wyschnegradsky's contracted octaves). The interactive principle governing the passage is that whenever the live electronics catch up to the module currently being played (ca. 16-second delay), the performer moves ahead to the next collection of pitches. Furthermore, with each successive module another pitch is appended, initiating an additive process that eventually passes through all twenty-four pitch classes of the quartertone system.³³ Arriving at the last two modules in the section, the piano's eighty-eight key range is exhausted, prompting a dramatic moment where Haas breaks the descending fourth sequence with a tritone. This, in turn, forces a pivot, in which the highest G on the piano loops around to the extreme low end of the instrument's register (G_1), where it reappears and resumes the cycle. Here, we find another tribute to Wyschnegradsky's thought as Haas contorts pitch space in these last two modules, eliding highs and lows by steering the sequence through what Wyschnegradsky called the "inaudible zone."³⁴

Figure 3b shows the voice-leading movement between harmonic modules in the first half of Section B. At each new stage, pitches that were previously played by the performer shift upward by quartertone in the electronics, and at the same time, the performer moves downward in a sequence of perfect fourths. As a result, the two parts interlock to form perfect binary divisions of non-octaviating major seventh spaces, yielding dense chordal stacks built

FIGURE 3a *Ein Schattenspiel*, Section B, part 1 (p. 7, first system), score excerpt illustrating contracted octaves in both the piano and electronics, interlocking into interval cycles of eleven quartertones and commencing the descending fourth sequence shown in Figure 3b.

Section B (start of harmonic sequence)

* Ped.

FIGURE 3b Voice-leading diagram of Section B, part 1 (p. 7, first system until p. 8, second system).

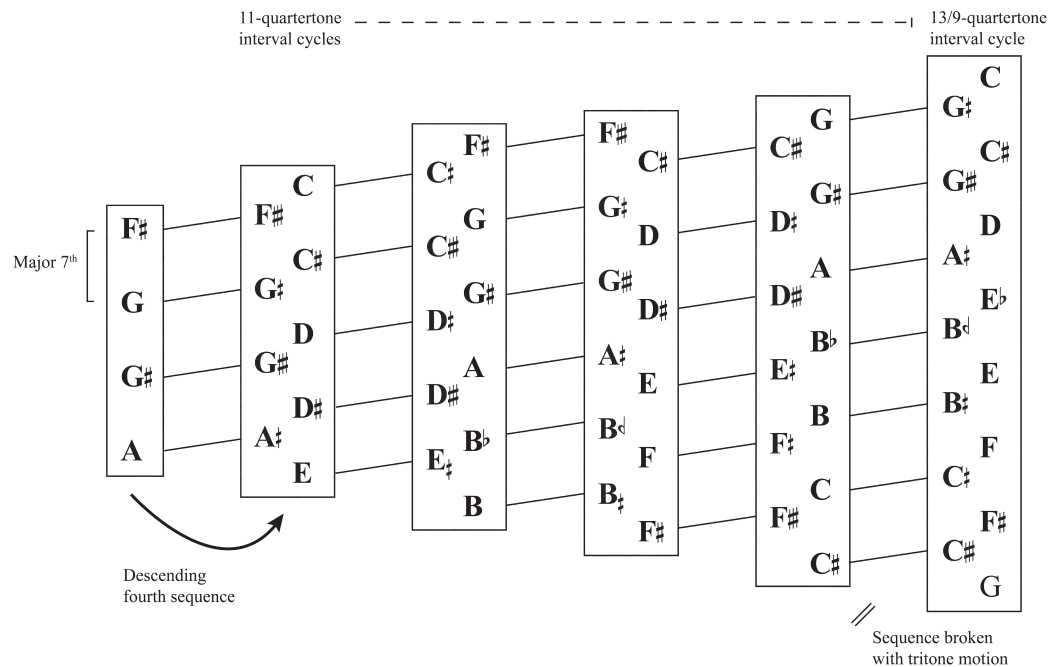

entirely from eleven-quartertone interval cycles. On top of this, the additive pitch process causes the register to expand in both directions so that, as each harmony planes downward, transient threads of ultrachromatic voice-leading drift upward, projecting a bi-rotational orientation to the overall sequence. The unexpected tritone descent in the last step of the sequence breaks the uniformity of this motion, causing the piano and electronics to vertically realign as a dual interval cycle alternating between thirteen and nine quartertones.

In the work's closing section, a final harmonic sequence features a reprise of the Wyschnegradsky chords at the precise moment when the live electronics seem to catch up to the performer. Shown in Figure 4a, the original delay of twenty-seven seconds has now diminished to less than two seconds, creating a confrontation between the two parts, which exchange a series of jolting

FIGURE 4a *Ein Schattenspiel*, closing section (p. 21, first and second systems), score excerpt illustrating dilated octaves in both the piano and electronics, interlocking into interval cycles of thirteen quartertones and commencing the ascending semitone sequence shown in Figure 4b.

The figure displays two systems of musical notation. The first system shows the initial part of the closing section, with a piano (Pno) and electronics (El) part. Both parts feature dilated octaves, indicated by a bracketed section. The piano part is marked *fffpp* and the electronics part is marked *fffpp*. A text box on the right side of the first system contains the following German text: "Wiederholen, bis sich ein Einrasten des Zusammenspiels zwischen Pf. und Elektronik entwickelt hat. Dabei entsteht ein allmähliches accelerando". The second system continues the piece, showing the piano part with an ascending semitone sequence in chord pairs, marked *sempre pp* and *crescendo*. The electronics part also shows an ascending semitone sequence in chord pairs, marked *sempre pp* and *crescendo*. A bracket at the bottom of the second system indicates the "Ascending 2nd sequence in chord pairs".

FIGURE 4b Voice-leading diagram of ascending second sequence in closing section, starting with the excerpt in Figure 4a.

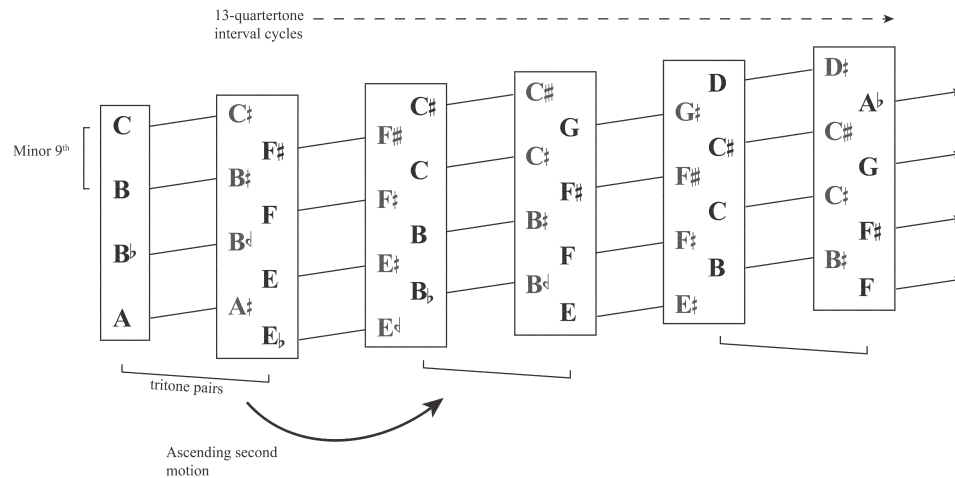

sforzando jabs before finishing in an unrelenting *accelerando*. Logic dictates that the performer must precede the live electronics in the timing of events; and yet, in these concluding bars, Haas manages to short-circuit time so that the past engulfs the present.³⁵

The basic harmonic unit of this last sequence is a tetrachordal stack of minor ninths, or “dilated” octaves, which ascend by semitone in tritone-related chord pairs. In Figure 4b, a voice-leading graph illustrates how the piano interlocks with a delayed and transposed version of itself, forming perfect binary divisions of these minor ninth frames (i.e., thirteen-quartertone interval cycle). Haas’s division of dilated non-octaviating spaces in the closing section provides a counterweight to the contracted spaces heard earlier in the work. In addition, the rising quartertone bass line in this final sequence articulates a kind of inversion writ large of the original cascading gesture from Section A (see Figure 2a), imparting an overarching sense of tonal symmetry.

To quickly summarize, in *Ein Schattenspiel*, Haas uses the reinjection loop as a means for realizing a quartertone system, within which the performer and live electronics interact to form perfect binary divisions of non-octaviating spaces. These “Wyschnegradsky chords,” as Haas refers to them, become iconic and referential sonorities that act as the markers of a prominent historical influence in his musical discourse.³⁶ The uninterrupted process of the reinjection loop and the consistent microtonal system it engenders is particular to this work and does not indicate a necessary limitation of the

35. For more on the causal relationship of instruments and electronics in mixed music, see Croft’s “Theses on Liveness,” 2007.

36. By contrast, Section C marks a departure from Wyschnegradsky’s sound world, shifting to what Haas describes as “the quartertone harmonic concepts of the late-Romantic Richard Heinrich Stein” (2007, p. 129). The section features a series of eleven ascending harmonies, all of which harbor vague tonal allusions and are linked together via ultrachromatic voice-leading.

technique, as will become evident in the following discussion of its more varied applications in Haas's fourth string quartet.

String Quartet No. 4 (2003)

Compared to *Ein Schattenspiel*, Haas's single-movement String Quartet No. 4 exhibits a much more complex formal design, which consists of three contrasting sections that return in a loose, rondo-like rotation. Within these cyclic returns, the defining features of each section intermingle, recombining into alternate configurations that blur the work's formal contours. Figure 5 outlines important details of the work's overall form.

FIGURE 5 String Quartet No. 4, overall form diagram showing how the quartet is recorded into multiple audio buffers (solid lines, labeled I–V) and then reinjected at a variety of tempos (dashed lines, with ratios of playback speeds indicated below).

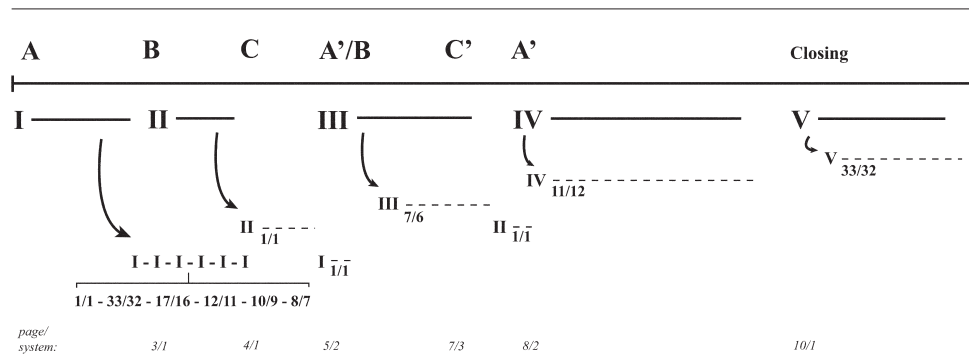

Mirroring the work's formal complexity, the reinjection loop in the quartet also follows a more sophisticated scheme. Instead of a single audio buffer (as in *Ein Schattenspiel*), there are five separate buffers, designated in the form diagram by roman numerals. The audio stored in each buffer is reinjected in a stop-and-go fashion, resulting in a flexible musical form with many moving parts. Likewise, the recorded audio is reinjected at several playback speeds, facilitating a wide variety of time-pitch transpositions. Through a juxtaposition of the transposed playback and new material played by the performers, Haas sets up a series of striking confrontations between different harmonic systems. Here, I will focus on just a few passages from the quartet, showing how Haas uses the reinjection loop to bring together all four approaches mentioned in his taxonomy of microtonal traditions; namely, equal-temperament, just intonation, sound-splitting techniques, and aleatoricism.

The work begins with all four instruments sustaining a soft drone (C_3 and C_4), and it is only through the intervention of extended playing tech-

niques that richer harmonic colors emerge. Here lies the first hint of aleatoricism, for as the string players massage the tone with quick dynamic swells, excessive bow pressure, and *sul ponticello* timbral shadings, uncontrollable partials appear and enter into spontaneous harmonic relationships. The only certainty in the introduction is a gradual opening of harmonic space, and the eventual arrival on a chord made up of overtones of a C-fundamental. Pictured in Figure 6a, these just-intoned pitches—which correspond to partials 3, 7, 11, and 21 above an assumed C₃-fundamental at 131 Hz—are supported by a reinjection of the initial drone in the live electronics (I). After the harmony locks in, the performers slide from these upper partials to new positions within a stack of alternating major sevenths and minor sixths. Despite the prominence of near-octave spaces in this dual-interval cycle, the sonority is perhaps closer to the Second Viennese School than Wyschnegradsky. Whatever its historical resonance, the harmony marks a definitive break with the opening of the piece, precipitating movement from a single harmonic system to a divided pitch space where the just-intonation overtone chord in the electronics is juxtaposed with a new equal-tempered harmony played by the live quartet.

FIGURE 6a String Quartet No. 4, end of Section A (p. 2, third system), just intonation chord moving to equal-temperament cycle of major sevenths and minor sixths (i.e., dual 11/8-semitone interval cycle). A sustained C drone is reinjected in the live electronics, providing a thread of continuity that unites the two harmonic systems.

The figure shows a musical score for the end of Section A of String Quartet No. 4. It features five staves: 1. VI., 2. VI., Va., Vc., and el. (electronics). The score is divided into three time intervals: ca. 5 sec., ca. 7 sec., and ca. 20 sec. The first interval shows a just intonation chord with partials 3, 7, 11, and 21. The second interval shows a glissando transition. The third interval shows a twelve-tone equal-temperament cycle of major sevenths and minor sixths. A box labeled 'I' indicates the reinjection of a sustained C drone. The score includes dynamic markings (pp, ff, mf) and glissando markings (gliss.).

FIGURE 6b Beginning of Section B (p. 3, first and second systems), reinjections of the just-intoned chord at different speeds produces a series of stepwise transpositions that rise by quartertone increments.

Reinjections of sustained C overtone chord

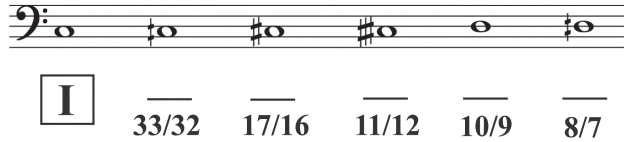

Following this initial shift in harmonic polarity, the members of the quartet maintain their respective pitches, but a degree of aleatoricism returns as they are given license to choose from a catalogue of rhythms, dynamics, and bowing articulations presented at the end of the score. Pictured in Figure 6b, the live electronics intermittently join the fray by reinjecting recorded samples of the initial overtone chord at different speeds: $33/32$, $17/16$, $12/11$, $10/9$, and $8/7$. Transferred to pitch space, these widening ratios closely approximate upward transpositions of the C-spectrum in quartertone increments. Notwithstanding the disorienting effects of the composite texture, it is possible to detect three distinct harmonic strains braided together—the equal-tempered dual-interval cycle played by the quartet, the overtone chord sounded by the live electronics, and the subsequent quartertone transpositions of this overtone chord in a scalar fashion.

A final example, shown in Figure 7, comes from Section A', a formal juncture that features a remarkable succession of harmonic systems chained together in a sequential relay. The excerpt begins with a homorhythmic cascade of whole-tone harmonies, which slowly dissolve as they repeat *ad infinitum*. Alongside this fading vamp, the electronics (buffer II) enter with the same dual-interval harmony heard earlier in Figure 6a. Against this held harmony, the quartet emerges with an overtone chord on a D-fundamental (partials 1, 3, 5, and 7). And finally, the D spectrum in the quartet is paired with a nearly immediate reinjection of itself (buffer IV) in the electronics at a decelerated ratio of $11/12$, yielding a new overtone chord that is approximately three quartertones lower than the original, with a fundamental on C-quarter-sharp. The superimposition of these two overtone chords exemplifies the Scelsian sound-splitting technique that Haas refers to as *Klangspaltung*. The expansive duration through which these nearby spectra evolve allows the listener ample time to grasp the shimmering, beating interferences produced

FIGURE 7 String Quartet No. 4, Section A' (p. 8, second system), overlapping of multiple harmonic systems.

Parallel whole-tone harmonies in equal-temperament

1. VI.

2. VI.

Va.

Vc.

2 Sekunden Pause

ca. 15 sec.

ca. 20 sec.

Bogenwechsel ad lib.

fff

fff

fff

fff

IV aufnehmen

II langsam einblenden (ca. 4 sec)
abspielen (Originaltempo)
Dynamik etwas leiser als das Original

IV ca. 1,66 Sekunden nach Beginn der Aufnahme abspielen (um den Faktor 11/12 verlangsamt wiedergeben) Dynamik etwa gleich stark wie das Original

11/8-semitone dual interval cycle

C[#] overtone chord

between their waveforms, presenting a classic example of Haas's observation that, when composing with microtones, it takes time for "the special intonational quality of the music to 'lock-in.'"³⁷ The close, interpenetrating proximities of multiple harmonic systems in this brief example give the music a strong sense of collage. As such, the passage embodies the pluralistic attitude that motivates so much of Haas's music.

37. Haas, 2007, p. 127.

Conclusion: Reinjection Loops and the Poetics of Pastness

The way Haas uses the reinjection loop in these early mixed works has an almost didactic quality. With only a virtual tape recorder to store and replay material, he establishes and parses various strains of harmonic (and by extension, historical) influence, plainly illustrating the co-existence of heterogeneous systems against the backdrop of a vast pansonorous continuum. Moving from *Ein Schattenspiel* to *String Quartet No. 4*, the preceding analyses chart a progression toward increasingly diverse pitch spaces. In the first piece, Haas works primarily within a single harmonic field, oriented around Wyschnegradsky's ultrachromatic quartertone system. The quartet, on the other hand, spirals outward from an initial just intonation system to a multipolar network of harmonic spaces—first with the establishment of a

bipolar opposition of just intonation and twelve-tone equal temperament (Figure 6a), then with the addition of quartertone divisions (Figure 6b), and finally, with the juxtaposition of several divergent pitch systems (Figure 7). In both pieces, the reinjection loop is deployed as an effective technical means for establishing musical spaces and moving freely among them. This fluidity is especially evident in the quartet, where access to multiple harmonic systems is made feasible by the malleable intonation of string instruments and the use of multiple audio buffers with variable playback speeds.

Beyond its technical role, the reinjection loop also functions as a hermeneutic device, invoking a poetics of pastness that brings Haas into communion with his compositional predecessors. As we have seen, the tape delay procedure itself is remediated inside the confines of computer software, highlighting its own status as a technological artifact. And in another sense, the reinjection loop acts as a container for musical memory, facilitating dramatic confrontations between the performer(s) and their recorded “shadows,” as well as between the composer and his creative influences. Exploiting the technique to produce iconic sonorities associated with a variety of musical traditions, Haas constructs a heteroglossic discourse that encompasses an extensive web of meta-textual references. In addition to working with formal relations between pitch spaces, he is forming unexpected musical connections between historical and cultural spaces.

As I have argued, it’s possible to understand Haas’s traversal of different sound environments as an extension of Wyschnegradsky’s law of pansonority, minus the latter’s regard for systematic orthodoxy. Wyschnegradsky was reacting against the hegemonic influence of pre-existing compositional models and he escaped tradition through his rationalization of pitch space in terms of mathematical divisions. But even as he left behind old systems, he built a new one that was even grander and more universalizing in its scope. By comparison, Haas works within an entirely different creative milieu—a “post-(post-) modern culture,” as Rutherford-Johnson calls it—that long ago loosened such restrictions and granted permission for composers to engage in pluralistic practices. To be sure, Haas has been influenced by Wyschnegradsky’s ultrachromatic theories, as well as his general philosophic outlook on the infinitude of musical space. He does not, however, share the elder composer’s systematic approach to “conquering” this virtual space, preferring to borrow from a range of historical strategies for constructing meaningful harmonic systems. At times, his borrowing is so direct and transparent that the music borders on pastiche, recalling Frederic Jameson’s description of art based on “the imitation of an idiosyncratic style, the wearing of a linguistic mask,

speech in a dead language [...] blank parody.”³⁸ Yet Haas’s use of prior musical codes is no empty simulation; it runs from evocative homage to critical subversion. No doubt, there are countless ways to interpret the audible presence of the past in Haas’s music, and the broad question of compositional influence presents itself as a rich field for further study. Focusing narrowly on his recent engagements with live electronic music, this paper has endeavored to shed some light on the subject, showing how the reinjection loop captures the ontological tension between original and copy, subject and shadow, present and past, as well as how these tensions mirror the plurality inherent in Haas’s compositional language.

38. Jameson, 1984, p. 65.

BIBLIOGRAPHY

- BAUER, Amy (2014), “The Harmonic Series is an Artifact: Ideology, Process, and Perception in Georg Friedrich Haas’s *in vain*,” Annual Meeting of the Society of Music Theory, November 6–9, Milwaukee, WI.
- BOLTER, David, and GRUSIN, Richard (1999), *Remediation: Understanding New Media*, Cambridge, MIT Press.
- CAMPBELL, Edward (2010), *Boulez, Music and Philosophy*, New York, Cambridge University Press.
- CROFT, John (2007), “Theses on Liveness,” *Organized Sound*, vol. 12, No. 1, pp. 59–66.
- FARTHOFER, Lisa (2007), *Georg Friedrich Haas: “Im Klang denken*,” Saarbrücken, PFAU-Verlag.
- FONSECA-WOLLHEIM, Corinna da (2016), “Finding Beauty in Georg Friedrich Haas’s Darkness,” *The New York Times*, February 28.
- HAAS, Georg Friedrich (1993a), “Die Verwirklichung einer Utopie: Ultrachromatik und nicht-oktavierende Tonräume in Ivan Wyschnegradskys mikrotonalen Kompositionen,” in *Harmonik im 20. Jahrhundert*, Vienna, wuv-Universitätsverlag, pp. 87–100.
- HAAS, Georg Friedrich (1993b), “*Arc-en-ciel*, Op. 3, Ivan Wyschnegradskys behutsame Annäherung an des Zwölfteltoninterval,” in *Mikrotöne IV*, Munich, pp. 79–92.
- HAAS, Georg Friedrich (1999), “Jenseits der Zwölf Halbtöne: Versuch einer Synopse mikrotonaler kompositionstechniken,” *Salzburger Festspiele*, Salzburg, pp. 17–23.
- HAAS, Georg Friedrich (2003), “Mikrotonalitäten,” in Hans Rudolf Zeller et al. (eds.), *Musik-Konzepte Sonderband: Musik der anderen Tradition: Mikrotonale Tonwelten*, Munich, Edition Text+Kritik, pp. 59–65.
- HAAS, Georg Friedrich (2007), “Mikrotonalität und spektrale Musik seit 1980,” in Jörn Peter Hiekel (ed.), *Orientierungen: Wege im Pluralismus der Gegenwartsmusik*, Mainz, Schott, pp. 123–29.
- HASEGAWA, Robert (2015), “Clashing Harmonic Systems in Haas’s *Blumenstück* and *in vain*,” *Music Theory Spectrum*, vol. 37, No. 2, pp. 204–23.
- HEILGENDORFF, Simone (2017), “Projected Resonance: Tonal Dimensions of Microtonal Composition in Music by Georg Friedrich Haas,” in Felix Wörner et al. (eds.), *Tonality Since 1950*, Stuttgart, Franz Steiner Verlag, pp. 283–94.
- JAMESON, Frederic (1984), “Postmodernism, Or, The Cultural Logic of Late Capitalism,” *New Left Review*, vol. 146, pp. 59–92.
- KEANE, David (1980), *Tape Music Composition*, Oxford, Oxford University Press.

- MASON, William (2017), “Exploring Liminal Spaces in Haas’s *limited approximations*,” Annual Meeting of the Society of Music Theory, November 2–5, Arlington, VA.
- REICH, Steve (2002 [1968]), “Music as a Gradual Process,” in Paul Hillier (ed.), *Writings on Music, 1965–2000*, Oxford, Oxford University Press, pp. 9–11.
- SCHOENBERG, Arnold (1975 [1941]), “Composition with Twelve Tones,” in Leonard Stein (ed.), *Style and Idea*, London, Faber and Faber, pp. 214–27.
- VARGA, Bálint András (2011), “Interview with Georg Friedrich Haas,” in *Three Questions for Sixty-Five Composers*, Rochester, University of Rochester Press, pp. 101–6.
- WOOLFE, Zachary (2014), “Ominous Stirrings in a Fitful Realm,” *The New York Times*, February 23.
- WYSCHNEGRADSKY, Ivan (1980 [1932]), *Manuel d’harmonie à quarts de ton*, Paris, *La Sirène musicale*.
- WYSCHNEGRADSKY, Ivan (1996 [1954]), *La loi de la pansonorité*, Geneva, Contrechamps.
- WYSCHNEGRADSKY, Ivan (1972), “L’ultrachromatisme et les espaces non octavians,” *La Revue musicale*, No. 290/291, pp. 71–141.
- WYSCHNEGRADSKY, Ivan (2013 [1978]), “Entretien avec Daniel Charles (Radio France),” in *Libération du son: Écrits 1916-1979*, writings collected and edited by Pascale Criton, Lyon, Symétrie, pp. 455–66.

WEB LINKS

- HAAS, Georg Friedrich (2010), “Program Note for *limited approximations*,” in online catalogue for Universal Editions, <https://www.universaledition.com/georg-friedrich-haas-278/works/limited-approximations-13386> (accessed May 12, 2019).
- HASEGAWA, Robert (2014), “Georg Friedrich Haas: Parcours de l’œuvre,” *Base de documentation sur la musique contemporaine*, Institut de Recherche et Coordination Acoustique/Musique (Ircam), <http://brahms.ircam.fr/georg-friedrich-haas> (accessed May 12, 2019).
- RATTLE, Simon (2013), “Programme for *in vain*,” London Sinfonietta performance on Friday, December 6, 2013, at Southbank Centre’s Queen Elizabeth Hall, https://issuu.com/london-sinfonietta/docs/haas_programme_for_issuu/6 (accessed May 12, 2019).
- ROSS, Alex (2010), “Let There Be Haas,” *The Rest is Noise Blog*, September 1, 2010, https://www.therestisnoise.com/2010/09/georg_friedrich_haas.html (accessed May 12, 2019).
- RUTHERFORD-JOHNSON, Tim (2013), “*in vain*, and the Discourse of 21st-Century Music,” *The Rambler Blog*, December 9, 2013, <https://johnsonsrambler.wordpress.com/2013/12/09/in-vain-and-the-discourse-of-21st-century-music/> (accessed May 12, 2019).

SCORES

- HAAS, Georg Friedrich (2003), *String Quartet No. 4*, Vienna, Universal Edition, UE 32 915.
- HAAS, Georg Friedrich (2004), *Ein Schattenspiel*, Vienna, Universal Edition, UE 32 945.